

Air Purifier



OWNER'S MANUAL

Welcome

Thank you for your purchase of the E-ZE3 Air Purifier. This small room air purifier has been designed to provide you a cleaner living space with years of low maintenance operation . Please read through the usage and service instructions out lined in this owner's manual.

Table of Contents

Diagrams/Warnings..... 3

Getting Started..... 4

Modes..... 4

Maintenance..... 4

Replacement..... 5





Specifications..... 6

Warranty Information..... 6

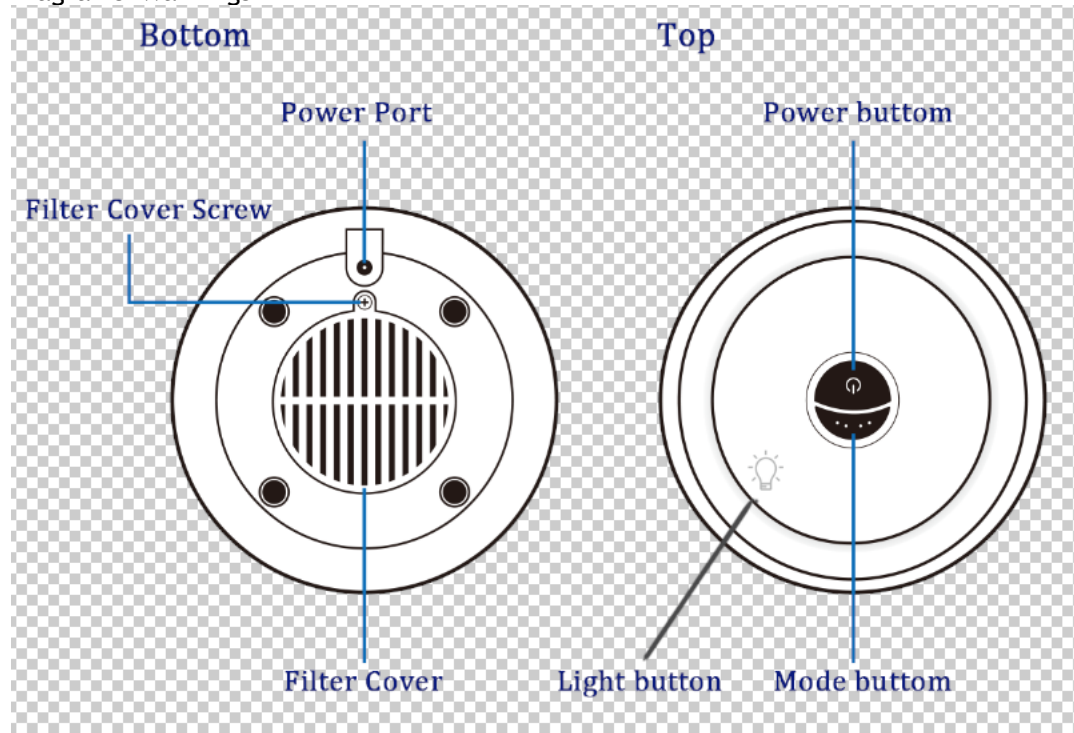
7

Diagrams/Warnings



-  Do not operate this unit unless it is completely assembled
-  Do not block the ventilation or filter.
-  Do not use Purifier Mode in an occupied space.
-  There are no user-serviceable parts inside the unit.
-  This unit is not intended for outdoor use.

Getting Started

1. Begin by removing the E-ZE3 and Power Adapter from the packaging. 2. Locate a suitable location to place your unit. (Ideal Location is an area of the room with good circulation, or near the source of your pollutant.)3. Plug the Power adapter into a wall outlet and then plug the other end into Power Port of your unit.4. Press the Power Button once turn your unit ON (begins in Ionisation Mode). Press it again to change to Purification Mode. Press it one more time to turn the unit OFF. 5. Press the Away Mode Button on the top of your unit to activate the Away Mode (Red Light).
2. Your unit will revert back to original mode after 30 Minutes

3.NOTE: Your unit will revert back to its previous mode after the 30 minutes cleaning cycle has ended. Away Mode can also be activated while the unit is OFF. Once complete, your unit will shut OFF.

Ionisation Mode (Green Light) Ionisation Mode is your unit's default mode. This mode utilises Ionisation ,which charges the particulates in the air until they clump together and fall out of your breathing space. The HEPA filtration with a carbon filter will add to removing airborne particulates such as smoke, pollen and pet dander.

Purification Mode (Blue Light) will in addition to the benefits of Ionisation, P create safe levels of Activated Oxygen(O3), which destroys bacteria, viruses, mold and mildew in the air and on surfaces.

The Away Mode (Red Light) High Power Purification Mode Creates Activated Oxygen(O3) and ionisation for a powerful 30 minute cleaning cycle before reverting back to the previous mode setting .

NOTE:Activated Oxygen can cause temporary respiratory and eye irritation. Keep people and pets out of the space when using Away Mode.

Light

The internal light can be turned ON/OFF by pressing the touch-sensitive Light Button on the top panel.

NOTE: The light will activate for 3 seconds when changing Modes with the light OFF to notify you of which mode is active.

Cleaning:

NOTE: For proper operation the unit should be cleaned at least once per month.

1. Turn the unit OFF and remove the Power Plug.
2. Carefully remove the Filter from the unit. **WARNING:** No Part of this unit should come into contact with water during cleaning.
3. Blow the filter out with compressed air or use a vacuum to remove any dust or debris.
4. Blow the interior of your unit out with compressed air.
5. Replace the filter , Filter Cover, and Filter Cover Screw.

6. Plug your unit in and return it to your previously set mode. If your unit has stopped working properly, if you need help, or have questions contact your dealer.
7. Filter life depends upon the level of pollutants in the space being cleaned. Filters should be replaced once every two months to ensure the highest quality of purification.

Specifications

Voltage.....	12V DC Power
Dimensions.....	160x160x230mm Net
Weight.....	654g Ozone
Output.....	.100mg/Negative
Ions.....	8 millions pcs/ cm ³ Effective
Area.....	Up to 250 sq meters
Warranty.....	1Year Manufacturer's Warranty



Warranty Information

Your E-ZE3 Air Purifier is warranted to be free from all defects in material and workmanship in normal household use for a period of 1 Year from date of purchase. The warranty is granted only to original purchaser and members of his or her immediate household. The Warranty is subject to the following provisions. Any damages or malfunctions caused by negligence, abuse, or use not in accordance with the Owner's Manual are not covered by this warranty. Likewise any defects or damages caused by unauthorised service are not covered. The dealer/manufacturer will at their option, repair or replace a defective Air Purifier that is covered by this warranty . As a matter of warranty Policy the manufacturer will not refund the customer's purchase price. To obtain warranty service you must return the defective Air Purifier along with proof purchase to the E-ZE3 Authorised Warranty Station. All transportation charges on parts, or units, submitted under this Warranty shall be borne by purchaser. Unless this Warranty is expressly renewed or extended by the dealer, any repaired or replaced part of the unit shall be warranted to the original purchaser only for the length of the unexpired portion of the original warranty.

FURTHER LIMITATIONS AND EXCLUSIONS ARE AS FOLLOWS:

Any warranty that may be implied in connection with your purchase or use of the Air Purifier, including any warranty of merchantability or any warranty for Fitness for a particular purpose is limited to the duration of this warranty . Some regions do not allow limitations on how long an implied warranty lasts, so the above limitations may not apply to you . Your relief for the breach of this warranty is limited to the relief expressly provided above. In no event shall manufacturer or dealer be liable for any consequential or incidental damages you may incur in connection with your purchase or use of the Air Purifier . Some regions do not allow the exclusion or limitation of incidental or consequential damages, so the above limitation or exclusion may not apply to you . This warranty gives you specific legal rights , and you may also have other rights which vary from country to country.

Travel Companion

Compact Size
Low Noise Output
Powerful Technology
Low Maintenance
1 Year Warranty



E-ZE2 is a small room air purifier that is ideal for traveling . Its compact size and powerful purification technology makes the E-ZE2 versatile enough for even the toughest situations. Pack the E-ZE2 away and plug it in wherever you stay to create a fresh healthy environment. Try combining the E-ZE3 and E-ZE2 in you home for more complete purification experience!